



FORD RANGER, EVEREST & SUPER DUTY

2022 - CURRENT

WITH 360° CAMERA

Towing Mirrors

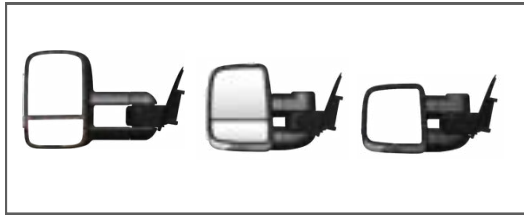

Power Boards and Swing Boards



Rock Tamers



Tyre Spider

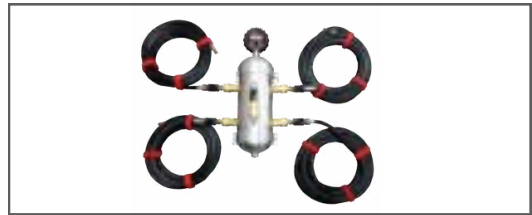

Easy Slides



Power Slides



Expanda Slides



Fridge Cage



Pantry

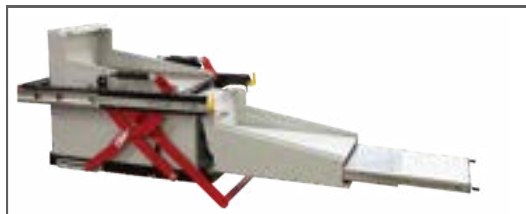

Cutlery Set



Clip on Trays

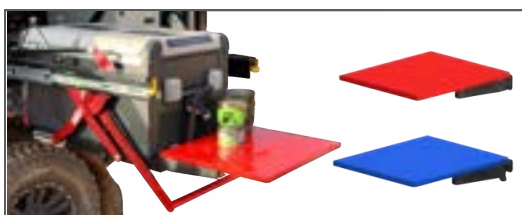

Cable Saver

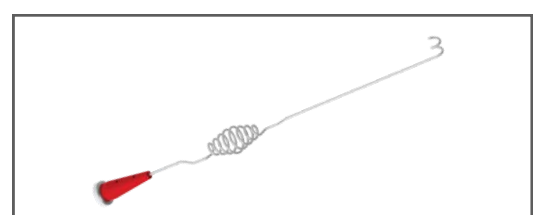

Thank you for choosing Clearview Accessories®

When it comes to road safety, having full visibility of your vehicle and your caravan, trailer or horse float is paramount. Clearview Towing Mirrors extend your field of vision when towing, changing lanes or reversing, to help see you to your destination safely. From Cape York's Telegraph Track to the Gibb River Road, Clearview Towing Mirrors are purpose-built tough for Australian conditions!

Clearview Accessories began in 2006, as a family run business owned by entrepreneur Mike Cowan and his son-in-law Jay Praag. In the years that followed, Mike and Jay turned their small family business with three full-time employees, into one of Australia's most respected 4WD and Touring Brands.

With a strong passion for the automotive industry, quality design and discipline in professional workmanship, our trust is built within our values of creating high quality ADR compliant designs.

From humble beginnings, Clearview Accessories has grown and today manufactures a range of unique, quality products for your next off-road adventure!

Contact us:

Clearview Accessories,
3 Frog Court, Craigieburn VIC 3064
Phone: (03) 8351 9933
Email: info@clearviewaccessories.com.au
Website: clearviewaccessories.com.au

Find us on social media

-  facebook.com/clearviewaccessories
-  instagram.com/clearviewaccessories
-  youtube.com/clearviewaccessories

Due to Clearview's Continuous Improvement Program, information may change without notice. Clearview takes no responsibility for the result of incorrect use of these installation instructions.

Our Range	2
Introduction	3
Getting Started	5
Before You Start	6
Maintaining Your Mirrors	7
Mirror Dimensions	8
Fitting Instructions	10-39
Ford Ranger & Everest Camera Removal	18-24
Ford Ranger Super Duty Camera Removal	25-32
FAQS	40
Troubleshooting	41-42
Warranty	43

Clearview mirrors are direct replacement mirrors that mount securely in the same position as your original mirrors.

What's in the box



- 1 x Left hand side mirror & base
- 1 x Right hand side mirror & base
- 1x 360° Camera Kit
- 1 x Installation instruction



360° Camera Kit



If anything is missing, or damaged, please do not install your new mirrors and contact us on 03 8351 9933 or via: info@clearviewaccessories.com.au

Tools Required:

- 'S'-Hook
- Torx 10 Key with Extension
- Torx 20 Key with Extension
- Torx 30 Key
- Soft plastic pry-bar (Trim Remover)
- Small Flat Blade Screwdriver
- Phillips head screwdriver



Whilst our mirrors can be installed by one person, the process is quicker and easier when an additional person is available to hold the mirror into position.

CAUTIONS | WARNINGS



CAUTION



WARNING

- Read through the fitting instructions before installation of Clearview Accessories.
- Always install the accessory following the fitting instructions. Failure to do so may cause damage to the vehicle or the accessory.
- Ensure all recyclable discarded vehicle accessory components and packaging are recycled following local recycling regulations.
- It is always recommended that this accessory is fitted by a qualified technician.
- Safely store and protect any removed vehicle components.
- Ensure all bare metal surfaces are protected using Automotive Bare Metal Primer and touch-up paint.
- Remove all metal swarf and dust from all vehicle surfaces if surface is used for accessory installation.
- Your Clearview Towing Mirrors should not be extended, unless you are Towing a Caravan or Trailer. (The Towing Mirrors have been certified as complying with requirement of ADR; 14/02, 6/00 and 13/00, when in the fully retracted position, fitted to a standard width/ unmodified vehicle.)
- **It is the recommendation of the Ford Motor Company that if you remove or disconnect the 360° Cameras on the vehicle, in order to ensure the full and correct operation of all 'Driver Assist Features' of your vehicle, that you need to arrange through your Ford Dealer for the performance of the Ford 'Camera Realignment Procedure', after the installation of your towing mirrors.**
- **Your vehicle maybe fitted with the Active Park Assist feature. You should only use this feature with your Towing Mirrors in the fully retracted, driving position.**

POWER FOLD

WARNING DO NOT UNFOLD MANUALLY

If your mirror is equipped with Power Fold. In some cases, the mirror head may be loose before installation as the mirror head needs to be electrically folded and unfolded for a minimum of cycles on its first use to synchronize.

Please refrain from folding the mirror MANUALLY as it can reduce the life span of the product.

Important: This mirror is designed to be manually folded upon impact as a safety feature.

COURTESY/PUDDLE LIGHT

Please understand that every car and every model are different, and that some vehicles have different wiring options to other vehicles. We do not know the exact wiring configuration of your vehicle.

If you require the use of the courtesy / puddle light function you will require the assistance of an Auto Electrician.

Clearview Accessories does NOT provide this service unless it's a standard function on the vehicle.

NOTE IF HARD WIRING: Orange Wire: Negative (-) | Grey Wire: Positive (+)

Maintaining Powder Coated Surfaces

Whilst powder coating is a lot more durable, and longer lasting than paint, it can still be affected by dust, dirt, salt water and constant exposure to the weather. For this reason, no protective powder coating is completely maintenance-free.

With the right maintenance, you can increase the life of the finish of your powder-coated surfaces:

- Harsh chemicals and solvents can damage the powder coating. Once damaged, the surface is a lot more vulnerable to fading and failure.
- We recommend regularly inspecting your powder coat and wiping any dust off with a soft cloth. Clean, good-quality microfibre cloths are recommended.
- We recommend regular washing with highly diluted mild soap and water. Use a soft towel to gently clean. Rinse and dry with another soft drying towel/chamois.
- If your powder coat is losing its shine, you can apply a thin layer of high-grade non-abrasive car wax after it's been cleaned. Wipe all the wax off once it's dried and the powder coat should look like new again! Use a car wax brand that contains a UV blocker or UV inhibitors. Do not use compound-type waxes as they contain abrasives that can harm the powder coating.
- It's important in coastal areas to regularly clean any powder-coated surfaces as salt will stick to the coating, dulling its appearance. This can leave your powder-coated surface looking chalky.
- We don't recommend paint touch-ups to cover imperfections as paint won't adhere to powder-coated surfaces. A local professional can quote to repair the powder coating.

How do I maintain my Powerfold mirrors?

Under regular Powerfold operation, there shouldn't be any maintenance required, however, if it is regularly used off-road, then the mirrors may need to be maintained every 6-12 months.

- This maintenance involves pulling the mirror into the fully extended position and applying dry lubricant on the arms, not the arm covers.

Maintaining your Chrome Mirrors

The chrome finish used on our mirror heads is a chrome-plated plastic, which provides the appearance and feel of real chrome, in a more lightweight and cost-effective material.

Weather conditions, how often they are washed and how close to the ocean you live, all play a role in the longevity of the chrome finish.

- Automatic car washes that use bristle brushes or acidic preparations can damage your chrome
- Salt and de-icers will surface pit chrome and extra care will be required with more frequent washes to remove residue.
- We recommend washing them weekly with mild soap and water, steering clear of ammonia-based or acid solutions.
- Clean, good-quality micro-fibre cloths are recommended to wipe down the chrome surface and prevent water stains from forming
- An occasional polish with a non-abrasive chrome polish will help bring your chrome back to its original shine!

NB: If chrome isn't properly maintained, it can develop pitting from corrosion or lose its attractive shine. We recommend **Autosol Metal Polish** and **Autosol Metal Life Saver**.

Compact Towing Mirrors

Non-Extended Standard Driving Position



Extended Towing Position

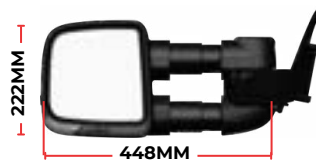

Fully Extended Towing Position

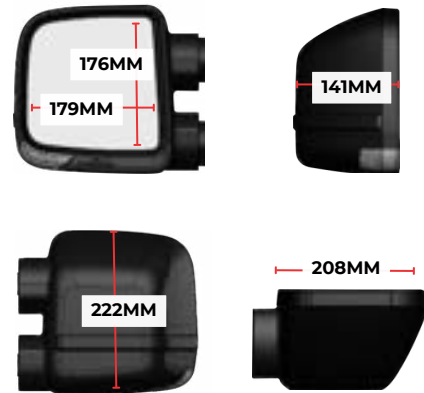
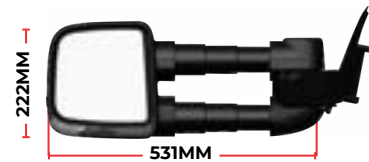

Next Gen Towing Mirrors

Non-Extended Standard Driving Position



Extended Towing Position

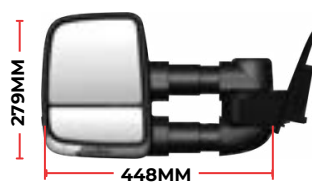

Fully Extended Towing Position

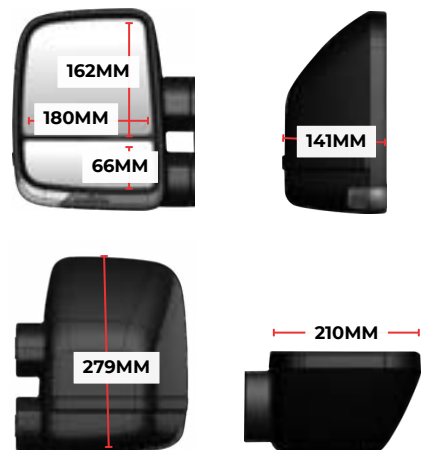
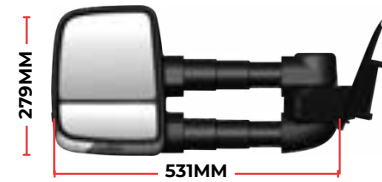



Your adventure awaits...
Let's begin!

IMPORTANT

Clearview Towing Mirrors to suit the Next Gen Ford Ranger & Everest are Licenced Ford Accessories. They have been built in conjunction with Ford Motor Company and are tested and approved by Ford for installation on the new Ranger and Everest models.

Your Next Gen Ford Ranger & Everest may be equipped with Driver Assist Features including 360-Degree Cameras, Reverse Brake Assist and Active Part Assist. When disconnecting and removing the original side mounted mirrors equipped with 360-degree cameras, these Driver Assist Features will be affected, and fault codes may be displayed in your vehicle.

When any camera has been disconnected and/or replaced in the Next Gen Ford Ranger or Everest, a Camera Realignment Procedure needs to be performed by an Authorised Ford Dealer to ensure the correct operation of all Driver Assist Features and to remove any displayed fault codes.

Installing Clearview Towing Mirrors (with 360 deg camera option) will therefore require a Camera Realignment Procedure. A Ford Motor Company dealer can perform this Camera Realignment Procedure once the installation and camera alignment process has been completed, as per the Clearview Mirror Installation Instructions.

You will need to make an appointment with your local Ford Motor Company Dealer as soon as possible after the installation of your Clearview Towing Mirrors. **The Ford Dealer will charge a fee** to perform this realignment procedure, which will be additional to the purchase cost of your Clearview Towing Mirrors and additional to the installation cost of your new mirrors.

Residual fault codes must be cleared for any future Ford software updates to be completed as any underlying issues may prevent a successful update.

Step 1

Prepare vehicle:

- Place transmission into park position with handbrake on.
- Turn ignition on and lower front door glass/windows
- Turn ignition off.

- Ford recommends that you disconnect the battery (disconnect the earth) prior to removing and disconnecting the side mounted mirrors. Refer to Ford Workshop Manual!



Step 2

Remove Corner Door Trim:



- Using Plastic Soft Lever Tool, insert, lever and remove the trim located in the lower front corner of the door window glass.
- Ensure you retain the 3 retaining clips on the trim.

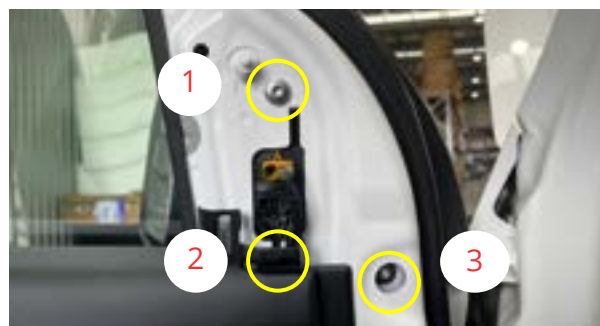

- This provides partial access to the mirror wiring plugs and to 2 of the 3 mirror attaching screws.
- Remove small plastic grommet to gain access to 3rd mirror attaching screw.

Step 3

Remove Door Handle Trim:



- Using a Plastic Soft Lever Tool, insert, lever and remove the small trim cover behind and around the door handle.
- Ensure you retain the retaining clips on the trim.
- This will reveal 2 Torx 20 head screws.
- Using the Torx 20 Key with the extension, remove these 2 screws.
- Retain screws for reattaching Door Trim.

Step 4

Remove Door Trim Screws:

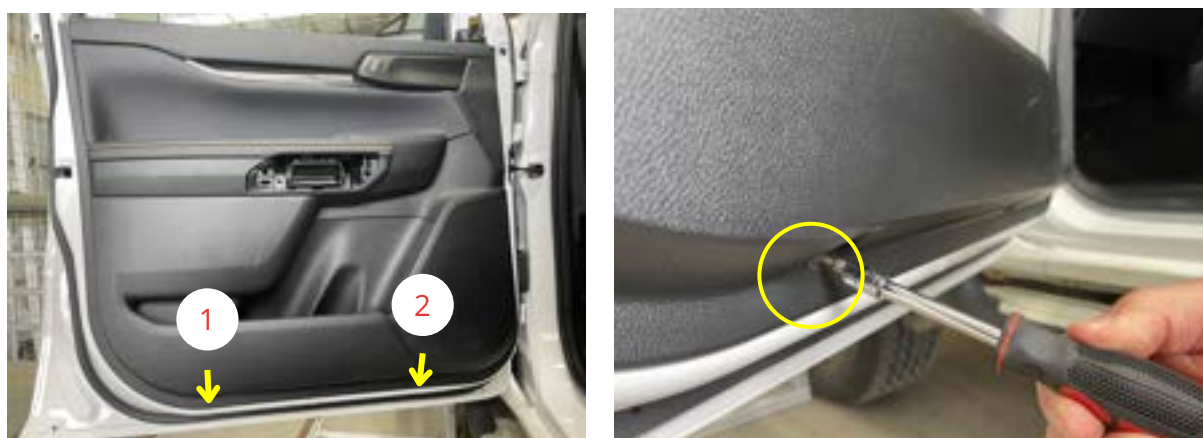

- Locate the 2 Torx 20 head screws at the bottom edge of the door trim.
- Using the Torx 20 Key, remove these 2 screws.
- Retain screws for later reattachment of Door Trim.

Step 5

Remove the Door Trim:



- Insert the Plastic Soft Lever Tool at the bottom centre cavity of Door Trim.
- Lever the Door Trim outward to disconnect from the retaining clips.
- Using your hands, continue to pull the Door Trim outward until all retaining clips have disconnected.
- Now, lift the Door Trim upward and position onto 'S' Hook, to support Door Trim during installation.

Note that the Door Trim must remain electrically connected to the vehicle door.

Step 6

Disconnect Mirror Wiring Plugs:

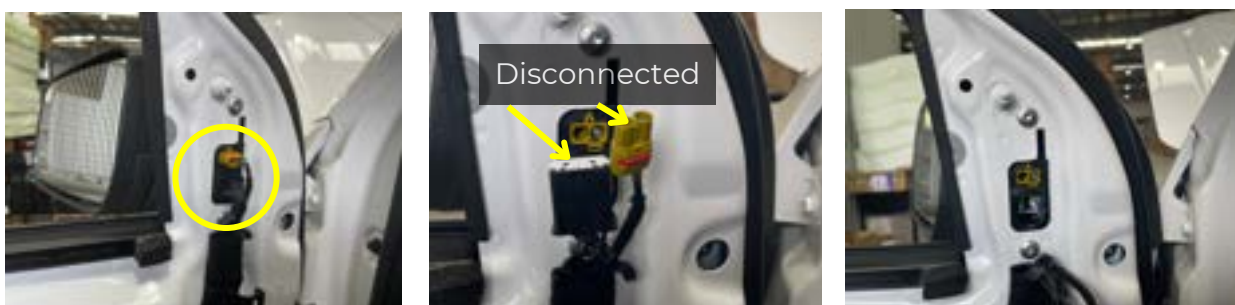

- You now have access to the mirror electrical connection wiring plugs which you will disconnect.
- **N.B. Ford recommends that you disconnect the battery (disconnect the earth) prior to removing and disconnecting the side mounted mirrors. Refer to Ford Workshop Manual!**
- Disconnect the single Black Multi Pin Plug, using the small flat blade screwdriver to release the retaining tabs.
- Disconnect the yellow 360° Camera Plug.

Step 7

Disconnect Mirror from Vehicle:



- Remove 3 of the Torx 30 Head, Mirror Head Mounting Screws.
- Support the mirror during this operation.
- Retain these screws for securing of Clearview Towing Mirror.
- Remove the mirror from the doors, by tilting the mirror upward to clear the hook at the top corner of the mirror base.



HANDY TIP: Keep your original OEM mirrors as back up should something happen to one of your Clearview Mirrors, necessitating the need to return it to us for repairs.

Step 8

Remove OAT Sensor from original Ford Mirror LHS only:)

Image is for Illustration purpose only



(OAT) Sensor



Pre Nov 2025 OAT Module shown

- Remove the Outside Ambient Temperature (OAT) Sensor Panel from the LH Mirror, as per Ford Workshop Manual.
- Unplug the wiring plug from the OAT Sensor using a small screwdriver to release retaining tabs.
- Remove the OAT Sensor from the panel by releasing single small retaining clip.
- **Note: The Small retaining clip is very fragile, so be careful when removing!**
- Retain sensor for later fitment to the LH CV Towing Mirror.

You are now ready to fit your new Clearview Towing Mirror

Step 9

Ford Ranger/Everest - OAT UPDATE 2026

1. If your vehicle was built in NOV'17th 2025 or later, (please refer to your dealer), the OEM mirror will be fitted with a modified Outside Air Temperature(OAT) sensor. Refer to the images below.

Ranger MY26 OAT sensor located under Mirror Head showing MY26 OAT Sensor



IMAGE A



IMAGE B



IMAGE C

2. If above Image B shown is the level of OAT in your OEM vehicle, and CV Mirror head has the purple OAT wiring harness (Image C) **then skip step 8, on page 14 of the Clearview Towing Mirror Installation instructions.** There is no need to remove the OAT from OEM Mirror as it cannot be re-used in the Clearview Towing Mirror. **(Until further notice)**
3. The supplied Clearview Tow Mirror Box - **CVNG-FD/CVC-FD** will include a FORD compatible OAT Sensor (**M2DZ 12A647 A**) kit provided as below image.



4. If the CV towing mirrors has below White connector OAT wiring harness in mirror head than you will have to remove the OAT module from Step 1 of your OEM Mirror head and also there will be no Kit provided in CV tow mirror box



5. **Please proceed to Step 15 on page 34 of the Clearview Towing Mirror Installation instructions and Install the Ford-compatible OAT sensor (M2DZ 12A647 A) onto the LAP bracket of the towing mirror, with or without 360° camera provision, as applicable to your vehicle as shown in the image below.**

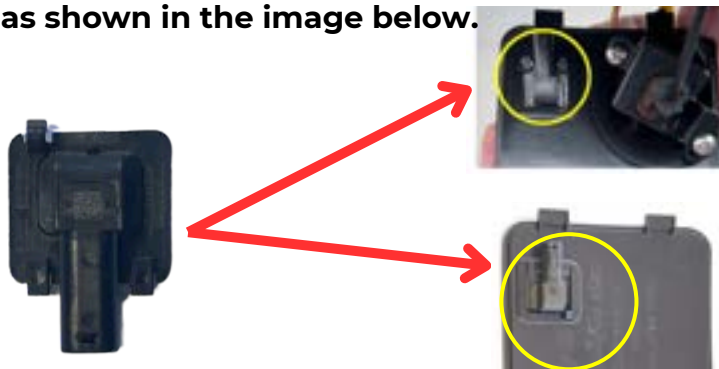

**LAP WITH 360°
CAMERA PROVISION**

**LAP WITHOUT 360°
CAMERA PROVISION**

Step 10

Remove the Towing Mirror etc. from the shipping box:

- Remove complete Mirror Heads from the box.
- Remove the 360° Camera Kit and put aside for later fitment of Camera.
- Ensure that the rubber gasket is securely located onto the Towing Mirror Base.

Note: For ease of handling the Towing Mirror during installation, extend the Mirror Head to the Mid Position.

Step 11

Attach the Towing Mirror to the Vehicle:



- Present the Towing Mirror Head Base to the Door Panel mounting position.
- Tilt the mirror head upward and position the hook at the top corner of the mirror base into and under the door mounting panel.
- Now tilt the mirror head down and push forward until the mirror base is completely inserted into the opening in the door mounting panel.
- Ensure that the 3 mounting holes are aligned to the 3 openings in the mounting door panel.
- Hand-start the 3 Torx 30 Head Screws, to avoid cross threading of the screws.
- Fully tighten all 3 Torx 30 Head Screws to secure the Towing Mirror Head to the vehicle door. Tighten to torque of 11Nm

Step 12

Electrical Wiring Connections from Vehicle to Towing Mirror:

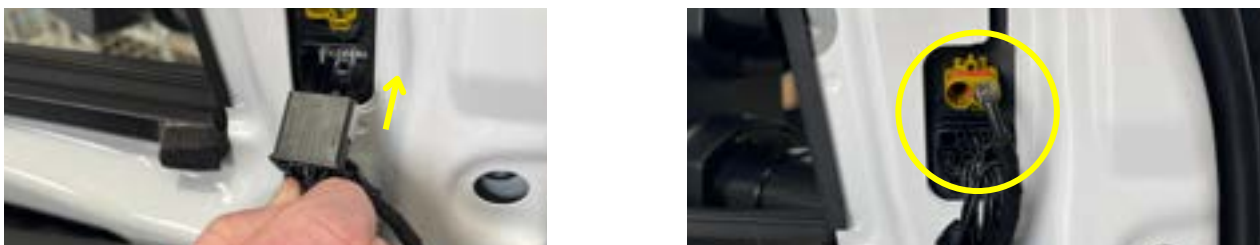

- Connect the Black Multi Pin Male Plug from the vehicle door wiring to the Towing Mirror Female Plug.
- Connect the yellow 360° Camera plug

Step 13

Reassemble the Door Trim:

- Lift the Door Trim off the 'S' Hook and position onto the door.
- Tap around the edges of the Door Trim to secure the Door Trim into the retaining Clips.
- Do not insert and tighten Screws.



Step 14

Installation of 360° Camera

Step 14a

Prepare mirror head for fitment of camera & lower access panel



1. If required remove blank lower access panel from underside of mirror housing.



3. Opening in mirror housing should be clear for fitment of camera lower access panel and to give access to camera wiring plug

2. Insert flat blade screwdriver end into slots and twist to 'pop' out lower access panel .

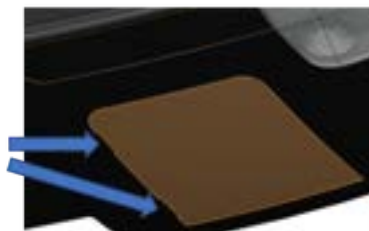

Image is for illustration purpose only

Step 14b

Remove parts from camera bracket kit

- Within the shipping box with the mirror head, you will find a camera bracket kit for your make of vehicle. This kit will contain:
- 1 x LH and 1 x RH camera lower access panels (parts marked/inscribed LH or RH)
- 1 x LH and 1 x RH camera brackets (parts marked/inscribed LH or RH)
- 4 x Camera bracket attaching screws

FORD RANGER & EVEREST

OEM camera removal only
2022- CURRENT (WITH 360° CAMERA)



Step 14c

Remove 'OEM' cameras from your original vehicle exterior mirrors

The 'OEM' cameras are located in the lower/outer corner of your original exterior mirrors



Location of OEM Cameras

N.B. Ford recommends that you disconnect the battery (disconnect the earth) prior to removing the OEM mirrors or disconnecting the mirror or camera wiring. Refer to Ford Workshop Manual.

The battery should not be reconnected until after the camera wiring is reconnected to the cameras in the new towing mirrors.

To remove the cameras (x2) from the original exterior mirror you must first remove the bezel and covers from the original exterior mirrors.

The following pages detail the procedure for the stripping down of the original exterior mirror and removing of the OEM Cameras

Remove Exterior Mirror Glass



1. Press mirror glass down in top inside corner.
2. Insert flat blade screwdriver into slot under glass and lever upward to separate glass from mirror glass motor.



3. Disconnect 2 x heater electrical connection from glass
4. Disconnect BSM electrical connection from glass

Remove Exterior Mirror Bezel & Cover

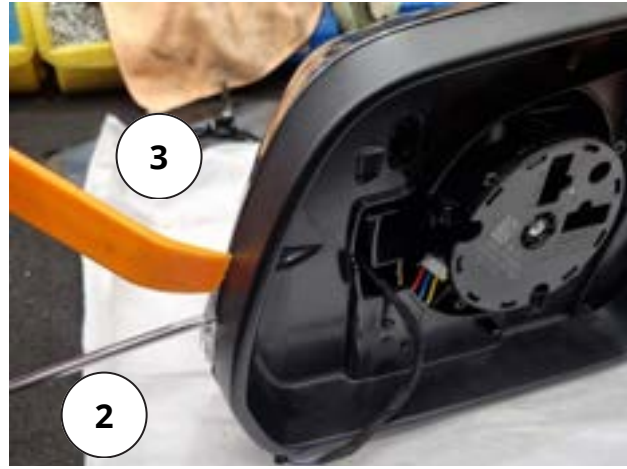

1. Remove 4 x exterior mirror bezel screws – using Torx 10 key.
2. Use flat blade screwdriver to separate bezel from cover.
3. Insert soft plastic pry-bar to lever the cover away from the Bezel



4. Work plastic pry-bar down the side of the cover, levering cover away from bezel until it pops free from bezel.
5. Release holding clip to enable cover to separate from bezel before working back across the top of exterior mirror.

Remove Exterior Mirror Bezel & Cover (Cont'd)



6. Now work the plastic pry-bar across top of exterior mirror and down inside edge of cover until it pops free. Continue to lever the plastic pry-bar to achieve this separation.

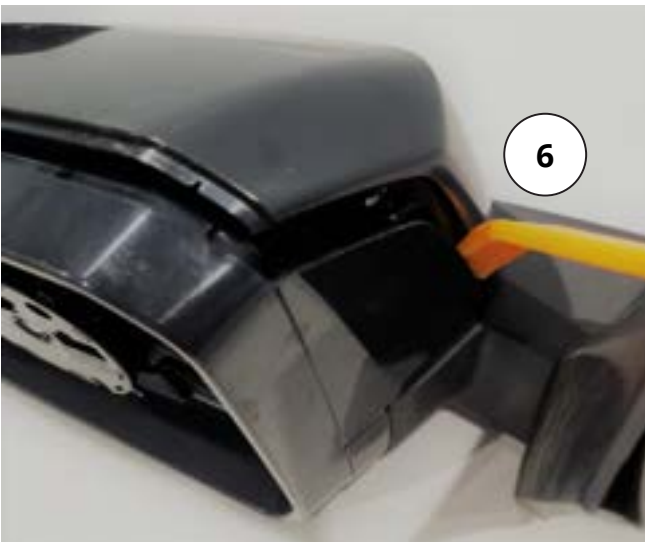

7. The exterior mirror cover can now be removed and the exterior mirror bezel can now be separated from the exterior mirror.

Remove OEM Camera and Camera Bracket from Exterior Mirror

Tip: Ensure that your left side 360 camera, is kept and installed with your left side Clearview Towing Mirror, and the right side is kept and installed in the right side.



1. You now have access to the OEM camera. It is located behind the turn signal at the base of the external mirror.
2. Remove the 2 x attaching screws using the Torx 10 key with extension bar to reach base of mirror.
3. These 2 screws attach the camera bracket which hold the camera in position.

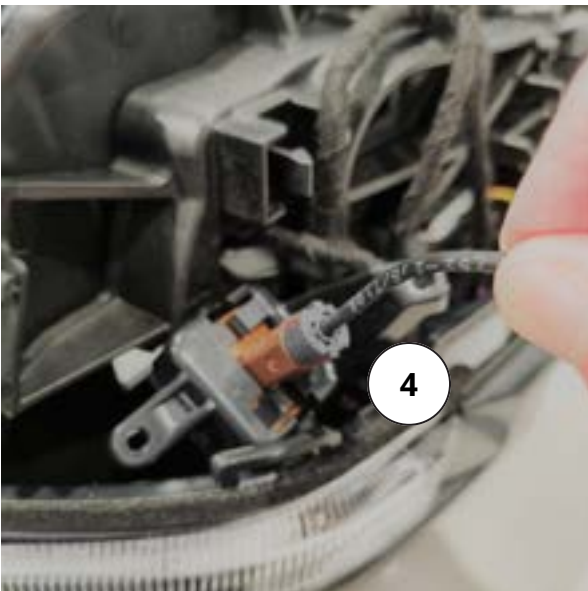

4. Use the camera electrical lead to gently pull the camera and bracket assembly up and out of the exterior mirror.

Remove Camera Bracket & Connecting Plug from OEM Camera



1. Push down on the release clip and pull upward on the wiring plug to separate the wiring plug from the OEM camera.

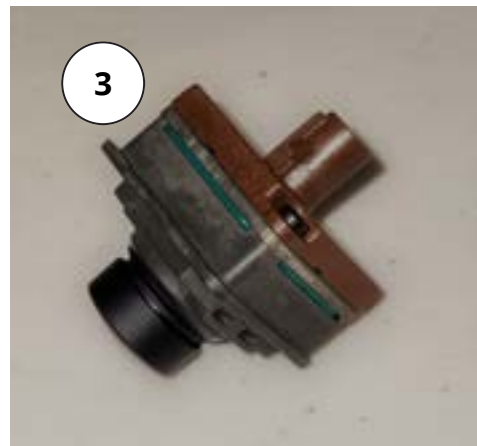
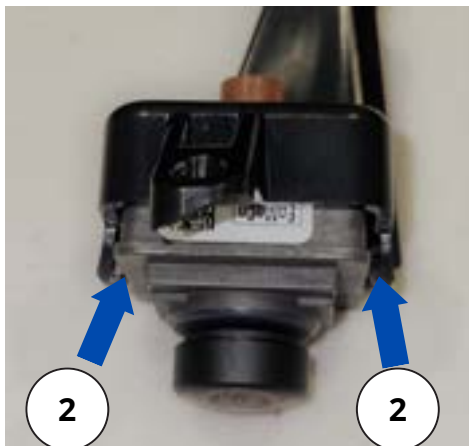

2. Release the 2 retaining clips, then separate the camera bracket from the OEM camera.

- You have now completed the procedure for removing the OEM cameras.
- You have 2 'OEM' cameras, available to install into your new Clearview Towing Mirrors.
- Ensure that you clearly identify the LH and the RH 'OEM' camera and you install them into the corresponding RH and LH towing mirrors
- This is how your OEM cameras should look with the wiring plug and retaining bracket removed.
Note the wiring plug retaining catch, you will later use this feature to ensure correct orientation of camera.

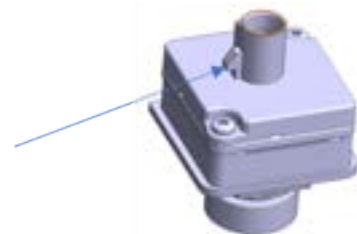

FORD RANGER SUPER DUTY

OEM camera removal only

2022 - CURRENT (WITH 360° CAMERA)

**Door Trim and Mirror Removal are
common to Ford Ranger Instructions*



Step 14c

Remove SUPER DUTY 'OEM' cameras from your vehicle exterior mirrors

The 'OEM' cameras are located in the lower/outer corner of your original exterior mirrors

LHS Mirror Head Shown



Before removing the OEM mirror cover, mark the edge of the camera (facing the glass) with white pencil/Chalk marker from the glass side of the mirror, to the middle of the camera as shown for both LH and RH side. This will ensure that when assembling it into the CV towing mirrors, the camera align correctly with the OEM position after the assembly.

To remove the cameras (x2) from the original exterior mirror you must first remove the bezel and covers from the original exterior mirrors.

The following pages detail the procedure for the stripping down of the original exterior mirror and removing of the OEM Cameras. After removing both of your OEM Mirrors, place them on a sturdy bench top.

Disconnect the battery by removing the negative terminal before taking off the OEM mirrors. Do not reconnect the battery until the camera wiring has been properly connected to the cameras in the new towing mirrors.

- After removing both of your OEM Mirrors, place them on a sturdy bench top.
- Locate the bottom of the OEM Mirror, where you can find the lens of your 360 Camera.
- With a white pencil, gently create a line, from the glass side of the mirror, to the middle of the camera (Image 1)



Image 1

Front Glass

- Once you have created your line, gently create a gap from the side corner by inserting a Plastic Pry tool as shown in Image 2 and Image 3



Image 2



Image 3

- Once the gap opens, insert the pry tool and gently press against the tabs to release the back cover. Take care not to apply excessive force to avoid damaging the tabs.



- There are three tabs securing the back cover. Once the first two tabs are released, the third will come off easily by gently opening the cover with your fingers and palm.



- With the back cover fully removed, set it aside in a safe place to prevent it from being lost or damaged to assemble it later.



Remove OEM Camera and Camera Bracket from Exterior Mirror

Tip: Ensure that your left side 360 camera, is kept and installed with your left side Clearview Towing Mirror, and the right side is kept and installed in the right side.

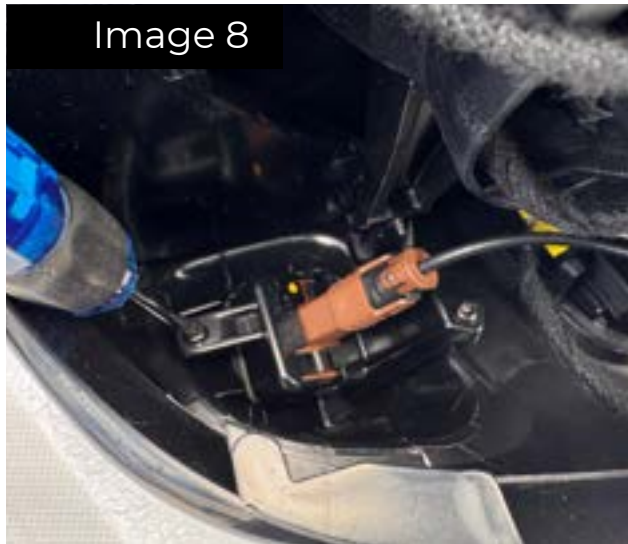

- You now have access to the OEM camera bracket which is located at the base. - Image 7
- Remove the 2 x attaching screws using the Torx T9 screwdriver head - Image 8
- Use the camera electrical lead to gently pull the camera and bracket assembly up and out of the exterior mirror - Image 9

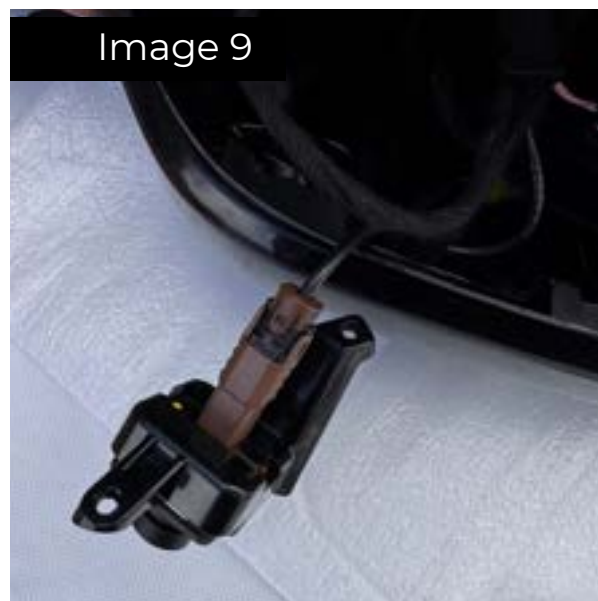

Remove Camera Bracket & Connecting Plug from OEM Camera



- Push down on the release clip and pull upward on the wiring plug to separate the wiring plug from the OEM camera.

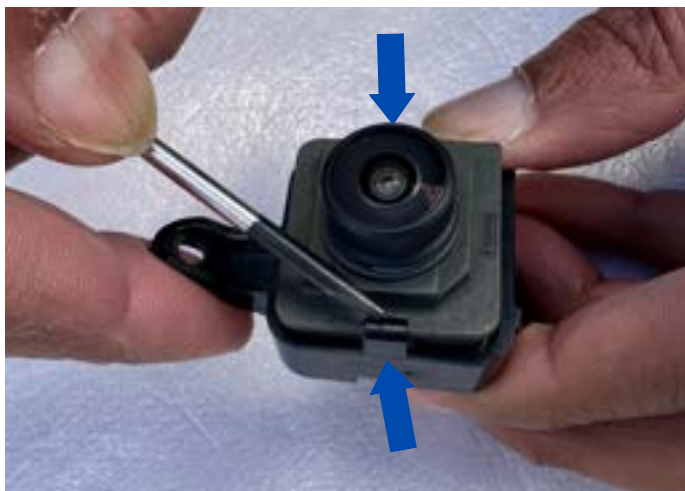

- Gently push the two side tab clips outward and lift the camera upward to release the camera bracket from the OEM camera.

1. You have now completed the procedure for removing the OEM cameras.
2. You have 2 'OEM' cameras, available to install into your new Clearview Towing Mirrors.
3. Ensure that you clearly identify the LH and the RH 'OEM' camera and you install them into the corresponding RH and LH towing mirrors

- This is how your OEM cameras should look with the camera bracket removed.

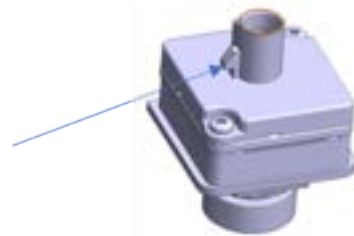

Please go to Step - 14D in Ford Ranger/Everest 2022 instructions for next steps of assembling OEM cameras to CV Mirrors.

Turn Signal non function in the CV Towing Mirrors

Note:

For all Ford Ranger Super Duty models, the OE Ford turn signals are disabled and relocated to the front RH and LH fenders (as highlighted) to comply with ADR 13/00 and ADR 6/00.

As a result, the turn signal integrated within the CV Towing mirrors will not operate on these vehicles.



Step 14d

Assemble 'OEM' cameras to new lower access panels

1. Assemble the 'OEM' cameras to the camera lower access panel and align the camera in position using the camera brackets and screws provided, as shown. Do not securely tighten the screws yet.

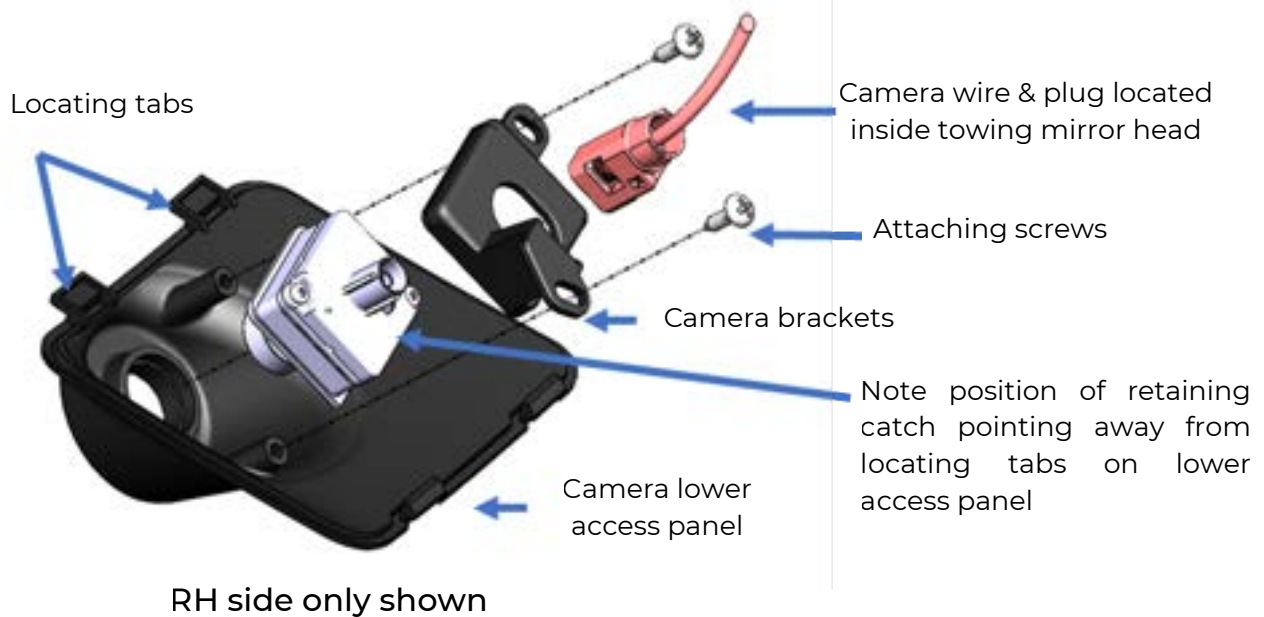

2. Align 'OEM' camera such that the camera bracket wings are positioned over the mounting lugs, as shown.

Note: camera wire & plug will be connected as part of the step 16

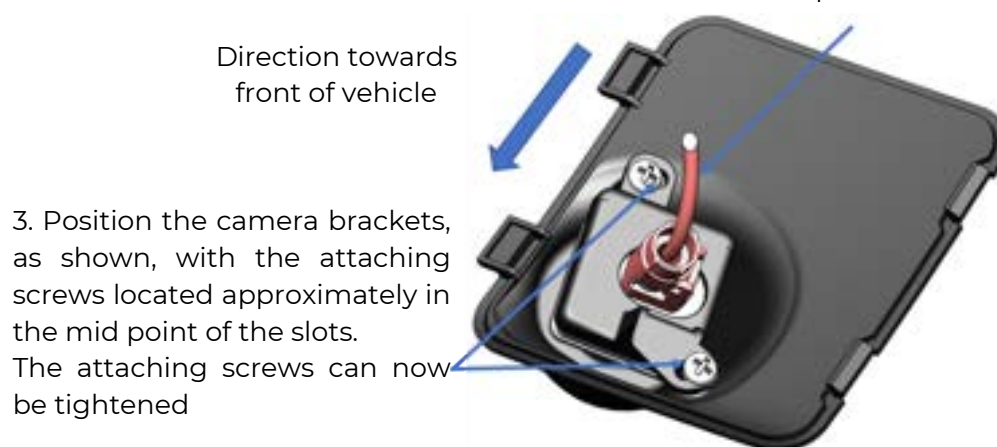

Step 15

Install & Connect OAT Sensor to Mirror Head (LH Mirror Only):

- Locate the LHS Access Panel from the 360° Camera Kit, removed from the shipping box in step 9.
- Locate the OAT Sensor removed from the OEM Mirror in Step 8.
- Fit OAT Sensor into opening in Lower Access Panel as shown.
- Push fully into position until clip engages.
- Locate OAT Sensor wiring & plug inside opening in base of Mirror.
- Connect OAT Sensor male plug into OAT Sensor female plug.

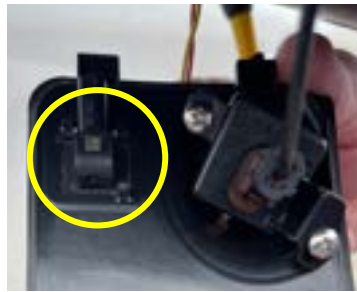
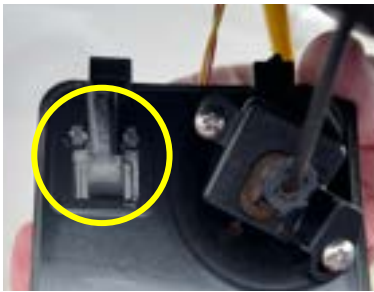

Pre Nov 2025 OAT Module shown. Assembly should be same for Post Nov 2025 OAT Module

POST Nov 2025 OAT Module

Step 16

Fit New Lower Access Panels with Camera & OAT Sensor to Towing Mirror Head

RH side only shown

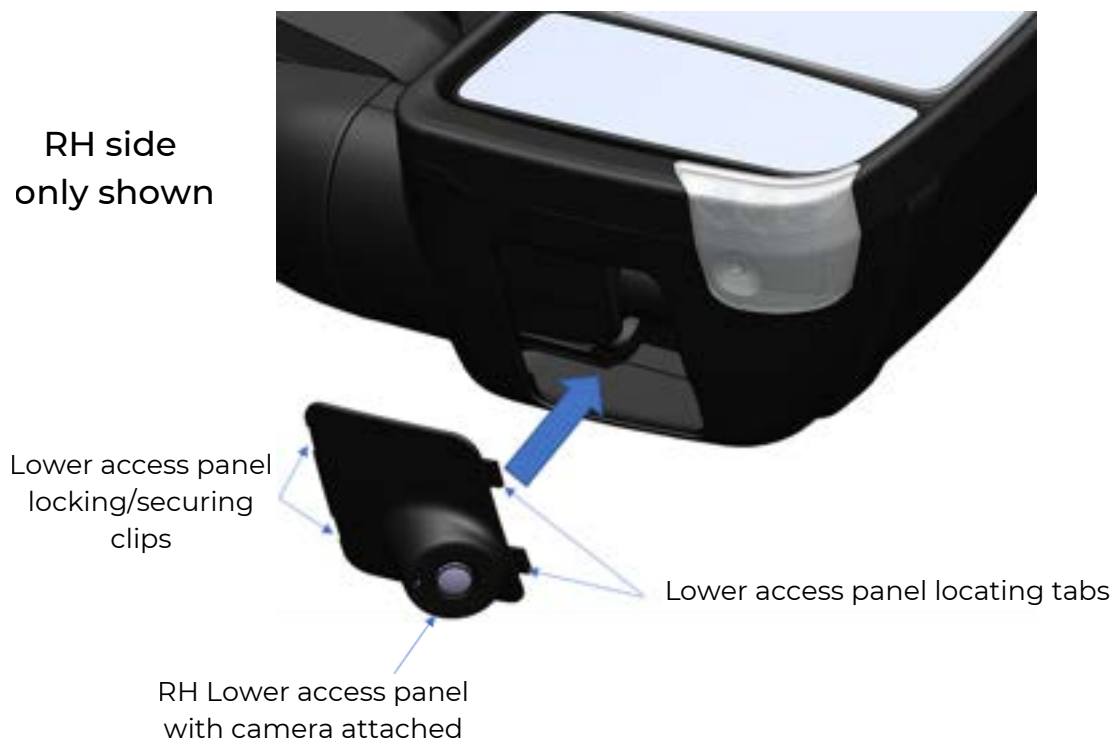

Image is for illustration purpose only

Fit New Lower Access Panels with Camera & OAT Sensor to Towing Mirror Head

With 'OEM' camera and OAT Sensor (LHS only) secured to the lower access panel – begin with right hand side mirror head

1. Locate the camera wiring plug immediately inside the opening in the bottom of the mirror head.
2. Connect this female wiring plug to the mating male plug on the camera. The wiring plug will only fit if correctly orientated with the retaining catch as noted on previous page.
3. Ensure the 2 mating plugs are completely connected.
4. Ensure OAT Sensor plug is firmly connect on LHS, as per step 15.
5. As you position the lower access panel to the mirror head allow the wiring to fit into the mirror head opening.
6. Ensure that the wiring is not trapped or interfering with the fitment of the lower access panel.
7. Position the lower access panel 2 locating tabs into the slots in the mirror head opening. These slots are on the outer side of the mirror head.
8. Now pivot the inner side of the lower access panel up until the locking clips are in contact with the mirror head opening.
9. Apply localise pressure to this edge of the lower access panel until the locking clips snap into position.
10. The lower access panel with camera and OAT Sensor assembly is now in position.
11. Repeat steps 1 – 9 for the LH side mirror.
12. You are now ready to test the alignment of your 360° cameras.
13. You can now proceed to reconnect your vehicle's battery (reconnect the earth). Refer to Ford Workshop Manual for instructions.

N.B. Ford recommend that you do not disconnect the wiring plug from the camera whilst the vehicle battery is still connected.

Step 17

Check Towing Mirror Functions

- If you previously disconnected the battery, you can now reconnect it. Refer to Ford workshop manual.
- Turn ignition on and operate the mirror function as applicable, in your Towing Mirror:
- Electric Mirror glass movement
- Power Fold of Mirror Head
- Mirror Head Turn Signals
- The OE Ford Turn Signals are disabled and added on front RH & LH fenders to comply with ADR 13/00 and ADR 6/00 on all Ranger Super Duty models only. Consequently the Turn Signal within the Towing Mirrors will not function on all Ford Ranger Super Duty vehicles.
- Mirror Head Curtesy Lights
- Blind Spot Monitoring
- Mirror Glass Heaters and
- OAT Sensor
- 360° Camera.

Step 18

Check and Adjust Camera Alignment on Vehicles

Preparation for testing:

1. Position vehicle on flat clear surface.
2. Ensure clear space of a minimum 1 meter each side of vehicle.
3. Place 2 parallel lines on the floor surface - 500-600mm away from vehicle wheels.
4. These parallel lines should run approximately the full length of the vehicle.
5. These parallel lines should be thick enough to be visible on vehicle 360° camera screen – approx. 50mm. The use of masking tape is suggested.
6. Refer to the vehicle owners manual for instructions as to how to access the vehicle 360° camera screen.



2 parallel lines on floor approx. 500-600mm away from vehicle

Check and Adjust Camera Alignment on Vehicles

View camera alignment

1. Turn on vehicle 360° camera screen – refer to vehicle owner's manual.
2. With Clearview towing mirrors firmly attached and electrically connected to vehicle and lower access panel & camera assembly securely in position, close all vehicle doors fully.
3. Ensure that the mirror heads are fully retracted and in the drive position. Operate the mirror fold feature to ensure in drive position.
4. Whilst seated in the vehicle, view the 360° camera screen to check the alignment of the parallel lines on the floor surface – the black lines.
5. You want to see these lines being parallel to the longitudinal lines of the vehicle – the yellow dotted lines, as shown.
6. If the lines are not parallel, you may want to adjust the angle of the camera on the lower access panel until these lines are parallel. Refer below for instructions on how to adjust the cameras.
7. The alignment of the Parking lines (Yellow) needs to be parallel to vehicle.
8. **Tip:** complete alignment on one side at a time. Open and close the respective door whilst viewing the lines on the screen. To determine if you need a clockwise or anti-clockwise adjustment.

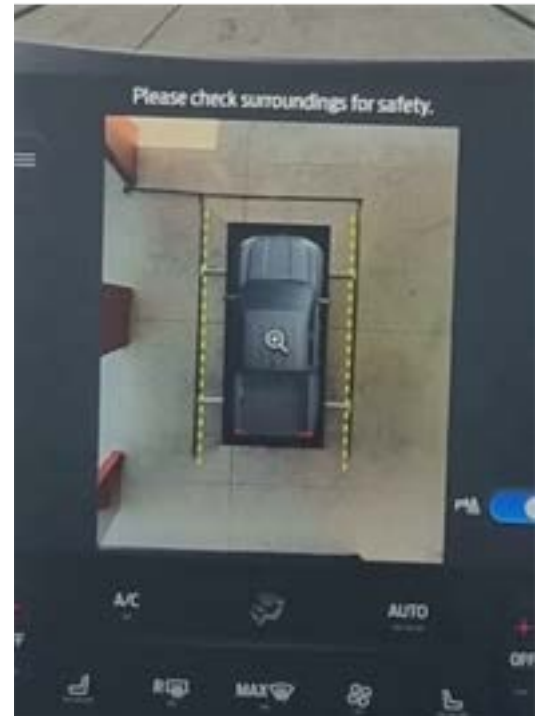

WARNING The 360° Camera from OEM has been relocated to CV Towing mirrors. So Parking Guidelines are approximate and might not be the same as OEM



Tip: complete alignment on one side at a time. Open and close the respective door whilst viewing the lines on the screen. To determine if you need a clockwise or anti-clockwise adjustment.

Check and Adjust Camera Alignment on Vehicle

Adjust camera alignment on vehicles

1. Keep the Vehicle ON in running Position - In Park mode and ensure all windows are fully lowered. Reach out and move the mirror head by hand on driver side to estimate the required direction—clockwise or anticlockwise—for adjustment OR you can follow the Tip mentioned on Pg.37 also.
2. Remove lower access panel, with camera attached, by unclipping 2 Tabs from Mirror head (as highlighted below in yellow) **(PN : Do not detach the camera cable from camera)**
3. Unscrew the 2 attaching screws just enough to enable movement of the camera bracket assembly.
4. Maintain downward pressure on the camera bracket so that it does not move prior to your adjustment.
5. Adjust the camera alignment by rotating the camera bracket & camera assembly a small amount, either clockwise or anti-clockwise.
6. Re-secure the 2 attaching screws to hold the camera in the adjusted position.
7. Re-fit the lower access panel, with camera secured in adjusted position, into the mirror head as instructed earlier.
8. Check now the 360° View on the screen OR move the Gear in Reverse to check the alignment of the Parking lines parallel to the Masking tape/bars as per previous step no. 10 instructed in 'View Camera Alignment'/'
9. Repeat 'adjust' & 'view camera alignment' steps until you are satisfied with the alignment of the parallel lines on both the RH and LH side of the vehicle.

2 attaching screws to be unscrewed for camera alignment adjustment

Adjust/rotate camera bracket & camera assembly, either clockwise or anti-clockwise, to achieve required adjustment



Congratulations! You have now fully installed your new Clearview towing mirrors with 360° cameras.

N.B. If you experience any issues with the ADAS features or 360° camera view after installing the Clearview mirrors, please consult a qualified diagnostics tool software technician at your vehicle's dealership

Step 19

Secure Door Trim:

- Using the Torx 20 Key, secure the same 4 Torx 20 Head Screws removed in Steps 3&4.
- Ensure that the screws are returned into the same position from where they were removed.



Step 20

Replace the Small Door Trims:



- Corner Door Trim (Step 2) and
- Door Handle Trim (Step 3)
- Push each of these trims into position and ensure they are secure, using your hands.

Congratulations! You have now fully installed your new Clearview Towing Mirrors and are ready for your next adventure!

N.B. It is the recommendation of the Ford Motor Company that if you remove or disconnect the 360° Cameras on the vehicle, in order to ensure the full and correct operation of all 'Driver Assist Features' of your vehicle, that you need to arrange through your Ford Dealer for the performance of the Ford 'Camera Realignment Procedure', after the installation of your towing mirrors.

Can I install Clearview mirrors myself?

Yes! Depending on the complexity of the installation, Clearview mirrors are extremely easy to install and mount to the vehicle's original OEM mirror mounts. Depending on the vehicle's current mirror options, Clearview mirrors include plug-and-play wiring looms. Instructional videos are also available on our website (clearviewaccessories.com.au) in the 'HOW TO' section. Clearview recommends that any installation requiring hard wiring be done by a licensed auto electrician.

What is the fitting time?

Depending on the complexity of the installation, the fitting will vary from vehicle to vehicle. Any installation requiring any special fittings and/or hard wiring will require longer fitting times (eg. 360° Camera fitting/calibration, any electric hard-wiring kits, OAT sensors, and any other complex installations etc).

NB: Fitting times will also vary depending on the skillset or capabilities of the fitter.

Please contact Clearview Accessories if you have any questions about fitting or wiring.

Are the telescopic arms electric?

No. The telescopic arms are extended manually. Clearview Mirrors will only fold against the vehicle electronically provided we make that model in Power Fold.

Can I retrofit the original mirror base to the Next Gen or Compact mirrors?

No. The cost of converting the mirrors to suit the new models is not worth it. We recommend either selling your Original mirrors privately or through the 'Pre-Loved' section (Within the 'Shop' menu category) of our website and purchasing the new Next Gen or Compact mirrors brand new.

Can I add an indicator later if I didn't order the mirrors with an indicator?

Yes, you can. But it comes at a greater expense than if you were to order the mirrors with indicators. Installation of the mirror head will require a longer time and more parts to dismantle.

Are spare parts available?

Yes. We have a list of spare parts for all our mirrors on our website. Our dealers also have a list of all our spare parts. If you cannot find the parts that you require, please contact Clearview Accessories, or any of our dealers to assist you with your enquiry.

How do I maintain my mirrors?

We recommend that Clearview Mirrors are lubricated every 6-12 months, when the arms feel stiff during use, or after any big trip to ensure longevity of your Clearview Towing Mirrors!



This maintenance includes pulling the mirror into the fully extended position and applying the dry lubricant on the arms. We recommend using WD-40 Specialist® Dry Lubricant.



Avoid any waxy lubricants as they can attract dirt and grit.

SCAN THE QR CODE AND VIEW OUR VIDEO DEMONSTRATING

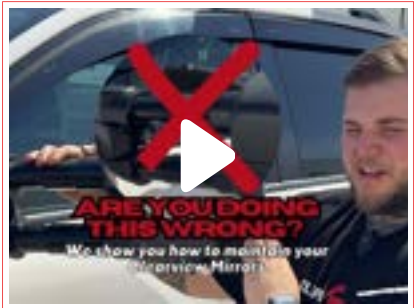
How to lubricate the arms on Clearview Towing Mirrors



I have just installed my new Powerfold mirrors and the mirror heads appear 'loose'/'floppy'.

After the mirrors are installed, they need to be cycled a few times. This will allow all the internal mechanisms to set and find the proper positions.

- If the mirror head is still loose/floppy after they're cycled, please contact Clearview Technical Support.

I have installed my Powerfold Mirrors and have noticed that the Passenger's side mirror is closer to the vehicle compared to the Driver's side; Is this normal?

This is entirely normal. In most vehicles, the mirror housings are angled differently between the driver's and passenger's sides.

- This is because when you sit in the car, the mirrors are positioned from/to the driver's position (which is off-centre), so generally, the passenger side mirrors are closer to the vehicle body to allow you to have the same field of vision in the mirror.

One of my Powerfold Mirrors folds/opens quicker than the other one; Is this normal?

Generally, the passenger mirror will fold/open quicker, as it is closer to the vehicle body and therefore travels a shorter distance compared to the driver's side mirror.

(Refer to the previous question in regards to why the mirrors are angled differently.)

My mirrors have been knocked out of Driving Position; how do I fix it?

Press the powerfold switch once. This should initiate the powerfolding motors and the mirrors should start folding inwards. Wait until the mirrors are fully folded in and have stopped moving, then press the powerfold switch again. This should now bring your mirrors back out to normal driving position. Check and see if the mirrors are locked into position firmly. If the mirror is not returning to its normal position, please contact Clearview Technical Support.

- **NB:** *The Powerfold mirrors can fold manually, however, the manual fold mechanism is only designed as a safety feature. Throughout the lifespan of the product, manual folding will occur, such as people walking into them or accidentally bumping them. The internal mechanisms are designed to withstand this accidental manual folding during normal usage. It is not recommended for the mirrors to be manually folded constantly, as it will prematurely wear out the internal folding mechanisms and reduce the lifespan of the product.*

My mirror was knocked out of the driving position. When I cycled them, there is a clicking sound and the mirror appears to have 'jumped'; Are my mirrors damaged?

When the Powerfold mirror is being cycled to find its original driving position, it will 'jump' back into position and make an audible click sound when mechanisms realign. Once the mirrors have found the original position and have been cycled, check for looseness and mirror movement. If they feel firm, then the mirrors have not been damaged. If they still feel loose, please contact Clearview Technical Support.

Why don't my mirrors fold all the way in/out when I press the switch?

The circuit breaker inside the mirror activates when the electrical current increases due to resistance. If the mirror stops before it reaches the folded in/out position, that means something is adding resistance while the mirrors are folding, hence activating the circuit breaker before it has reached the desired position. Please contact Clearview Technical Support.

Clearview Towing Mirrors® are full replacement towing mirrors designed and manufactured to the highest quality standards to replace your vehicle's standard side mirrors. We stand behind our Next Gen and Compact Towing Mirrors with a 3-year Manufacturer's Warranty and 7-year Parts Warranty. We stand behind our Original Towing Mirrors and Classic Towing Mirrors with a 12-Month Manufacturer's Warranty and 3-year Parts Warranty

Please ensure that your receipt is kept in a safe place. A receipt will be required to make a warranty claim on any Clearview product. If we determine that a Clearview Towing Mirror is defective in materials or workmanship during the Warranty, we will either repair or replace the product. Repair or replacement is solely at the discretion of Clearview Accessories.

Please ensure that you fit the Clearview products in accordance with the product information provided and all relevant vehicle safety and compliance laws; and use the Clearview product for the purpose for which it was originally designed. This warranty does not apply to failure or damage caused by incorrect or faulty fitment, accidental or intentional damage, alteration, acts of nature, vandalism, collision, road hazards or adverse conditions, misuse, abuse or neglect of the Clearview product, including improper repair or maintenance or failing to repair and maintain the product, failure of other products, operation of the product outside of its environmental or technical specifications, or repair or modification carried out by anyone other than Clearview Accessories®. No charges will be accepted for external labour or materials without the prior advice or clearance from Clearview claims team. Clearview Accessories® warranty does not cover any scratches or chips.

Clearview Towing Mirrors are designed to be vehicle-specific. When purchasing Clearview Towing Mirrors, carefully select your product according to ADR compliance laws and vehicle specifications. Clearview Towing Mirrors are not designed to be modified for convenient use on alternative vehicles. Alteration, modification, or manipulation of our products will void all warranty with Clearview Accessories.

All claims under this warranty should be lodged through our website warranty section <https://www.clearviewaccessories.com.au/about/warranty/> with the detail of the fault, proof of purchase, proof of identification and vehicle fitment details where relevant. If your claim is accepted for defects in material or workmanship Clearview will, at its discretion, offer to repair, replace parts, or return and refund.

Our goods come with guarantees that cannot be excluded under the Australian Consumer Law. You are entitled to a replacement or refund for a major failure and for compensation for any other reasonably foreseeable loss or damage. You are also entitled to have the goods repaired or replaced if the goods fail to be of acceptable quality and the failure does not amount to a major failure. In the event of a minor failure, the company reserves the right to choose to repair or replace the product.

Clearview Towing Mirrors® | ABN: 59 140 145 393 | 3 Frog Court, Craigieburn VIC 3064
Phone: (03) 8351 9933 | Email: info@clearviewaccessories.com.au



Head Office

3 Frog Court, Craigieburn
VIC 3064, Australia
(03) 8351 9933

QLD Office

Unit 1/49 Doherty Street, Brendale
QLD 4500, Australia
(07) 3204 7693

info@clearviewaccessories.com.au

clearviewaccessories.com.au

